

UHD 4K CAMERA

User Manual **(V1.0)**

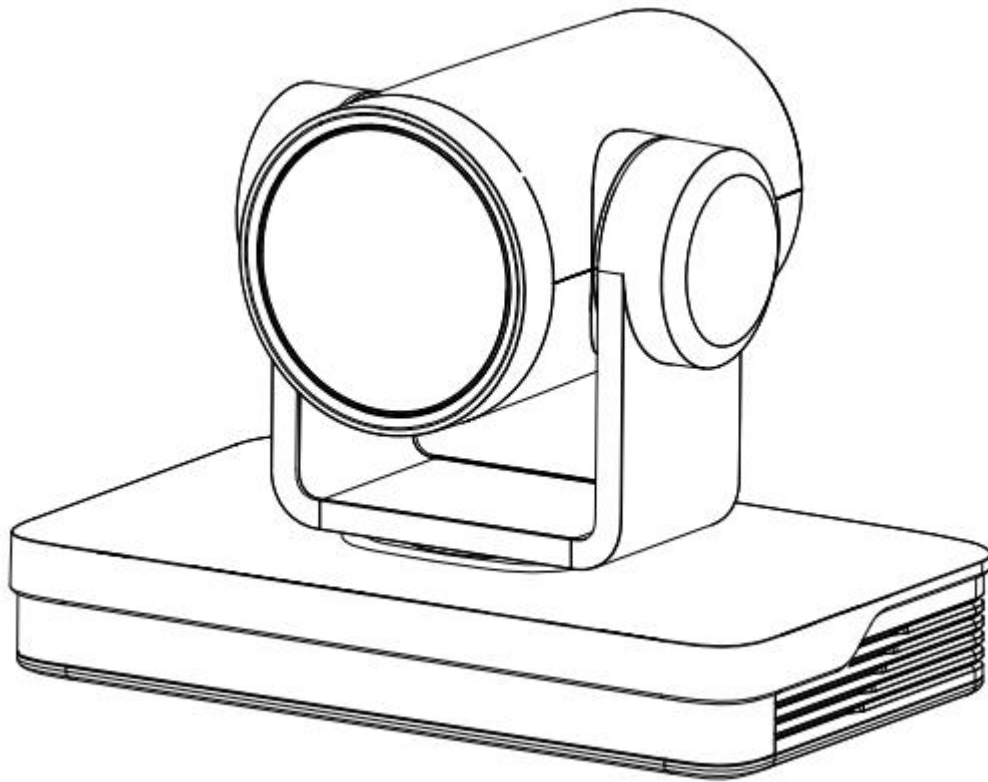



Attentions

This manual introduces functions, installations and operations for this 4K camera in details. Please read this manual carefully before installation and use.

1. Cautions

- 1.1 Avoid damage to product caused by heavy pressure, strong vibration or immersion during transportation, storage and installation.
- 1.2 Housing of this product is made of organic materials. Do not expose it to any liquid, gas or solids which may corrode the shell.
- 1.3 Do not expose the product to rain or moisture.
- 1.4 To prevent the risk of electric shock, do not open the case. Installation and maintenance should only be carried out by qualified technicians.
- 1.5 Do not use the product beyond the specified temperature, humidity or power supply specifications.
- 1.6 Wipe it with a soft, dry cloth when cleaning the camera lens. Wipe it gently with a mild detergent if needed. Do not use strong or corrosive detergents to avoid scratching the lens and affecting the image;
- 1.7 This product contains no parts which can be maintained by users themselves. Any damage caused by dismantling the product by user without permission is not covered by warranty.

2. Electrical Safety

Installation and use of this product must strictly comply with local electrical safety standards. The power supply of the product is $\pm 12V$, the max electrical current is 2A.

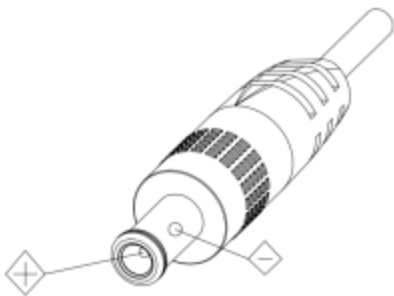

3. Install

- 1.1 Do not rotate the camera head violently, otherwise it may cause mechanical failure;
- 1.2 This product should be placed on a stable desktop or other horizontal surface. Do not install the product obliquely, otherwise it may display inclined image;
- 1.3 Ensure there are no obstacles within rotation range of the holder.
- 1.4 Do not power on before completely installation.

4. Magnetic Interference

Electromagnetic fields at specific frequencies may affect the video image. This product is Class A. It may cause radio interference in household application. Appropriate measure is required.

Content

1. Camera Installation.....	- 4 -
1.1 Camera Interfaces	- 4 -
1.2 Power-on Initial Configuration	- 4 -
1.3 Video Output.....	- 5 -
1.4 Mounting Brackets.....	- 5 -
2. Product Overview	Ошибка! Закладка не определена.
2.1 Product Introduction.....	- 7 -
2.1.1 Dimension.....	- 7 -
2.1.2 Accessory.....	- 8 -
2.2 Main Features	- 8 -
2.3 Technical Parameter.....	8
2.4 Interfaces Instruction.....	- 10 -0
2.4.1 External Interface	- 10 -0
2.4.2 RS-232 Intergface.....	- 11 -1
3. Application Instruction	- 13 -
3.1 Video Output.....	- 13 -
3.1.1 Power-on Initial Configuration.....	- 13 -3
3.1.2 Video Output	- 13 -3
3.2 Remote Control	- 13 -3
3.2.1 Match Code for Wireless Remote Control.....	- 14 -3
3.2.2 Keys Introduction for IR Remote Control	Ошибка! Закладка не определена. 4
3.3 Menu Introduction.....	- 17 -
3.3.1 Main Menu	- 17 -
3.3.2 System Setting	- 18 -
3.3.3 Camera Setting.....	- 19 -9
3.3.4 P/T/Z.....	- 22 -
3.3.5 Video Format	- 23 -3
3.3.6 Version.....	- 23 -
3.3.7 Restore Default	- 24 -4
4. Network Connection	Ошибка! Закладка не определена. 4
4.1 Connecting Mode.....	- 24 -4
4.2 IE Login	- 26 -6
4.2.1 Web Client	- 26 -6
4.2.2 Preview	Ошибка! Закладка не определена.
4.2.3 Playback.....	- 27 -7
4.2.4 Configuration	- 27 -7
4.2.5 Video Configuration.....	Ошибка! Закладка не определена.

4.2.6 Network Configuration.....	- 30 -
4.2.7 System Configuration	31
4.2.8 Logout	32
5. Serial Port Communication and Control.....	Ошибка! Закладка не определена. 3
5.1 VISCA Protocol List.....	- 33 -
5.1.1 VISCA Protocol Return Command.....	- 33 -3
5.1.2 VISCA Protocol Control Command	- 33 -
5.1.3 VISCA Protocol Inquiry Command	- 36 -
5.2 Pelco-D Protocol Command List	- 38 -
5.3 Pelco-P Protocol Command List.....	- 38 -
6. Maintenance and Troubleshooting	- 39 -
6.1 Camera Maintenance.....	39
6.2 Troubleshooting.....	Ошибка! Закладка не определена.
7. Copyright Statement.....	Ошибка! Закладка не определена.

1. Camera Installation

1.1 Camera Interfaces

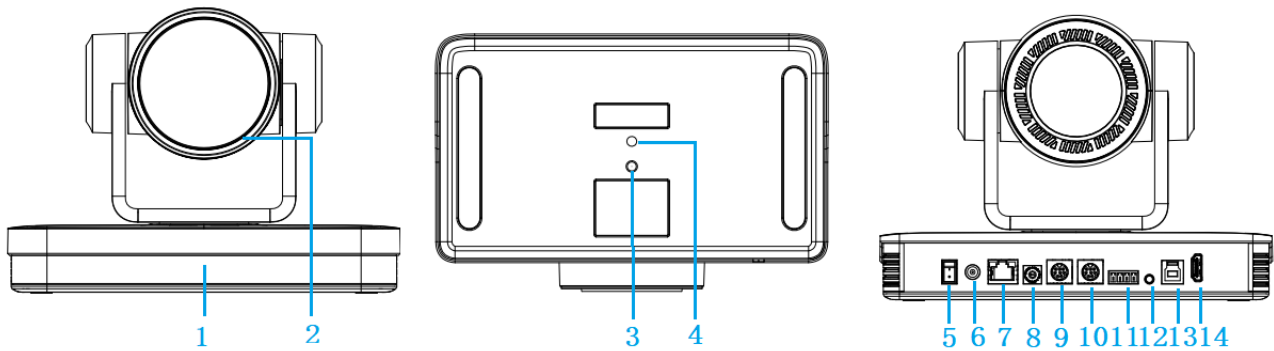

Figure 1.1 Product Interfaces

- | | |
|---------------------------------------|---------------------------------------|
| 1. Remote Control Receiving Indicator | 8. Rotary DIP Switch |
| 2. Camera Lens | 9. RS232 Control Interface (input) |
| 3. Tripod Screw Hole | 10. RS232 Control Interface (output) |
| 4. Screw Hole for Tripod | 11. RS422/RS485 Input |
| 5. Power Switch | 12. Audio Input Interface |
| 6. DC12V Input Power Supply Socket | 13. USB 3.0 Interface |
| 7. LAN Port | 14. HDMI Output Interface |

1.2 Power-on Initial Configuration

1) Power-on: Connect DC12V power supply adapter with power supply socket

2) Initial Configuration: The remote control receiving indicator flashes after power on, the pan-tilt turns left to the lowest left to the lowest, and then turns to the HOME position (both the horizontal and vertical positions are in the middle), while the movement first shrinks and then stretches. When remote control receiving indicator stops flashing, the self-checking is completed.

Notes:

- 1) After power on and self-checking, the camera will automatically return to the preset 0 position if it's pre-set.
- 2) The default address for the IR remote control is 1#. If the menu restored to factory defaults, the remote control default address will restore to 1#.

1.3 Video Output

- 1) Network output
 - a. Network cable connection: as shown in Figure 1.1 label 7
 - b. Webpage Login: open your browser and enter 192.168.5.163 (factory default) in the address bar; press Enter to enter into the login page, click on the "player is not installed, please download and install !" and follow the installation steps for installation. Then enter the user name *admin* and password *admin* (factory default); press Enter to enter into the preview page, users can carry out PTZ control, video recording, playback, configuration and other operations.
- 2) HDMI Video Output
 - a. HDMI video cable connection: as shown in Figure 1.1 label 14
 - b. Connect the camera and the monitor via HDMI video cable, and the video output is available after the camera self-test.
- 3) USB3.0 Video Output
 - a. USB 3.0 video cable connection: as shown in Figure 1.1 label 13
 - b. Connect the camera and the computer via USB3.0 video cable, open the video software and select the image device to output the video.

1.4 Mounting Brackets

Notes:

Ceiling or wall mounting brackets can only be mounted on template and concrete wall.

For safety reason, plasterboard is not recommended.

1) Wall Mounting

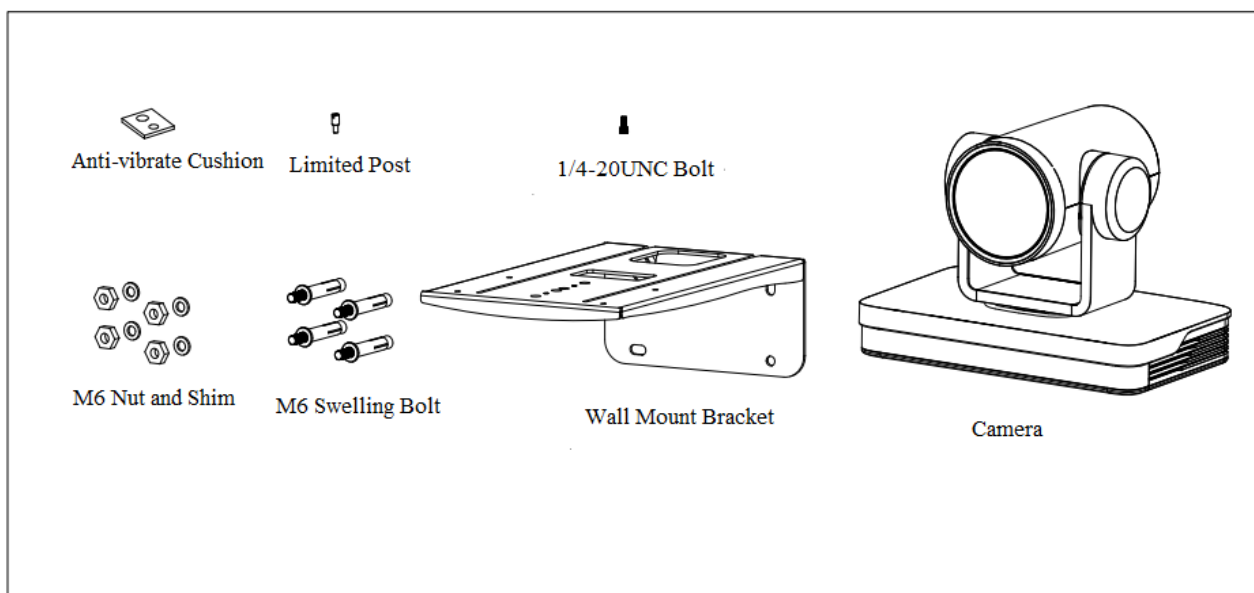

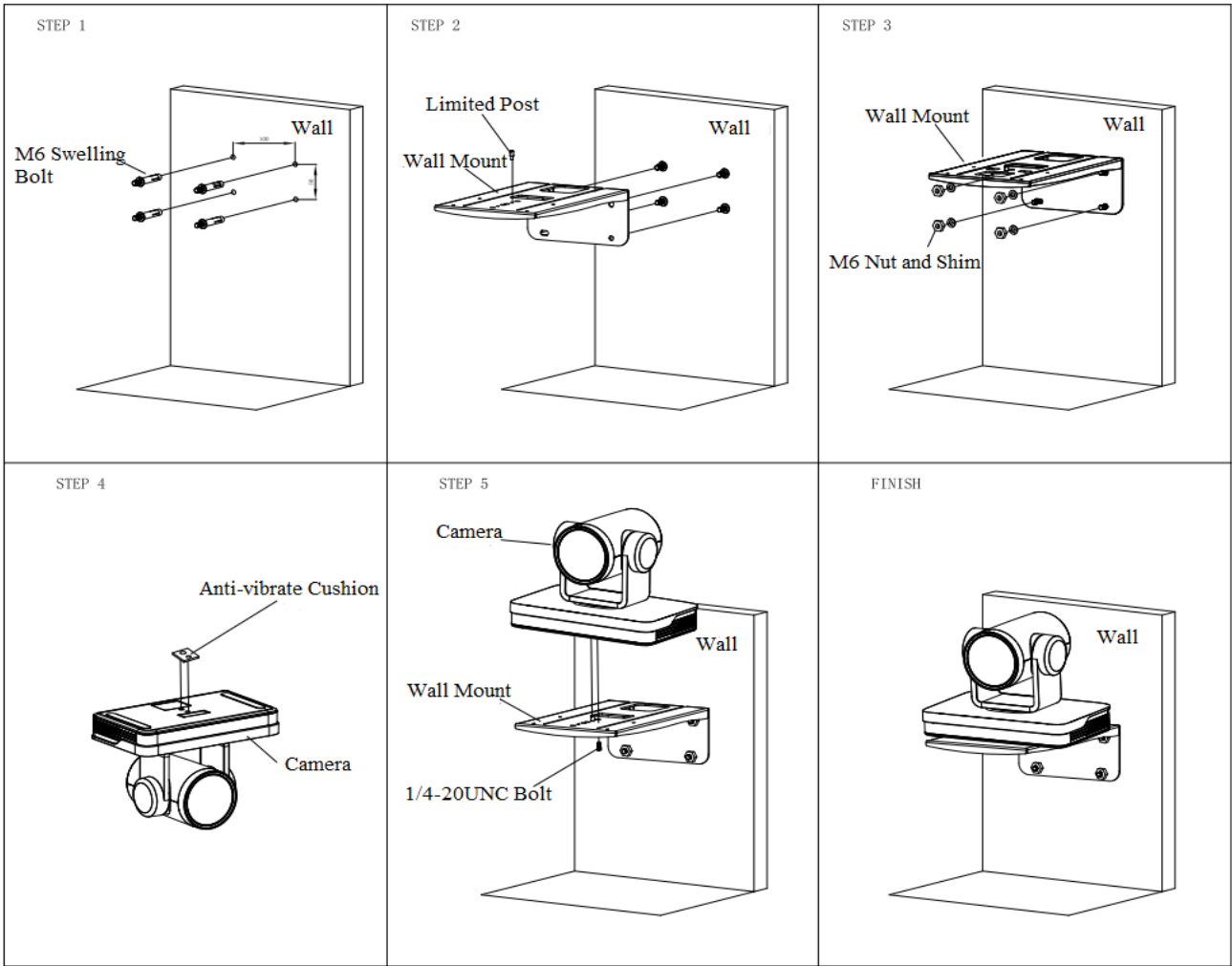

2) Ceiling Mounting

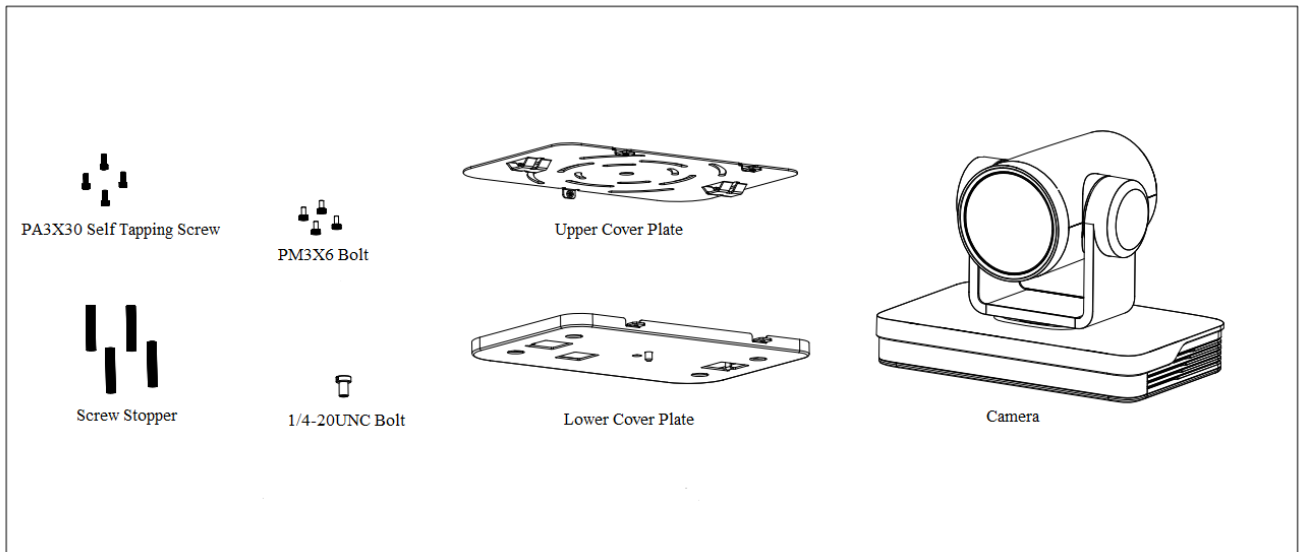

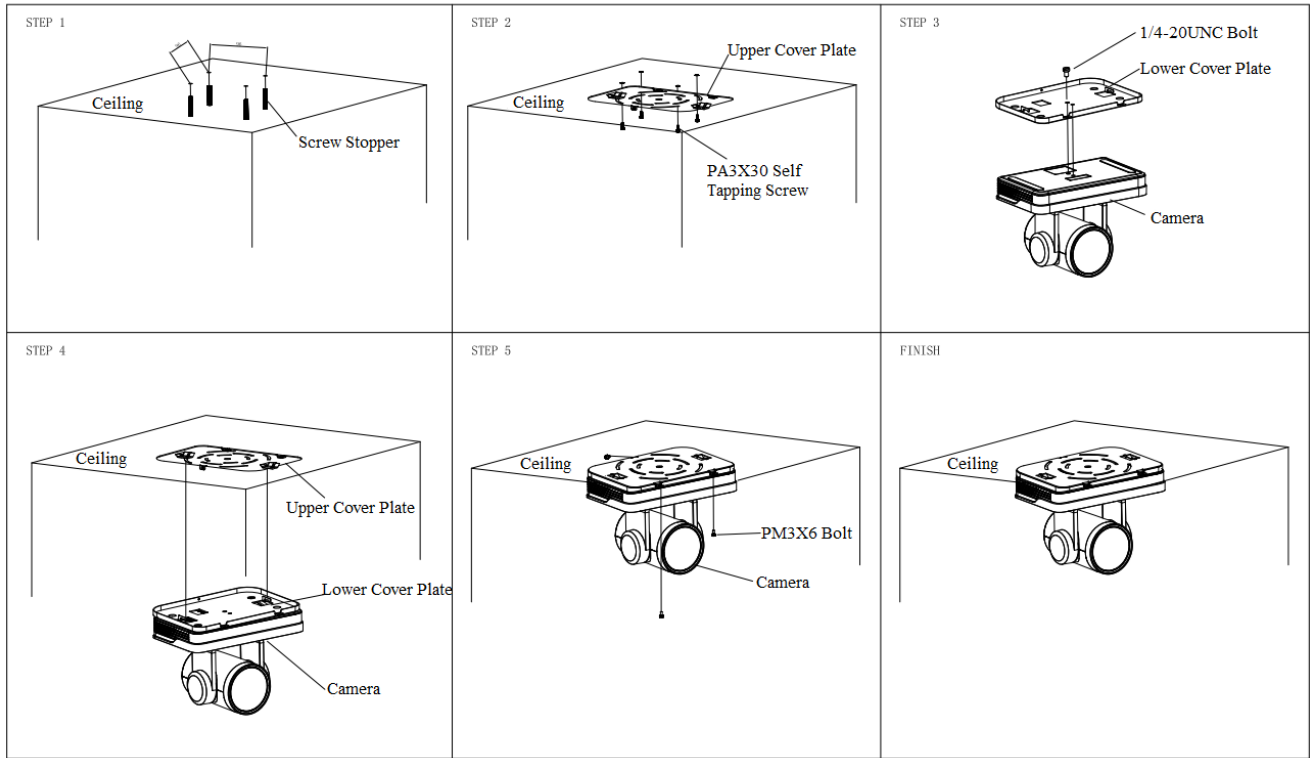

2.Product Overview

2.1 Product Introduction

2.1.1 Dimension

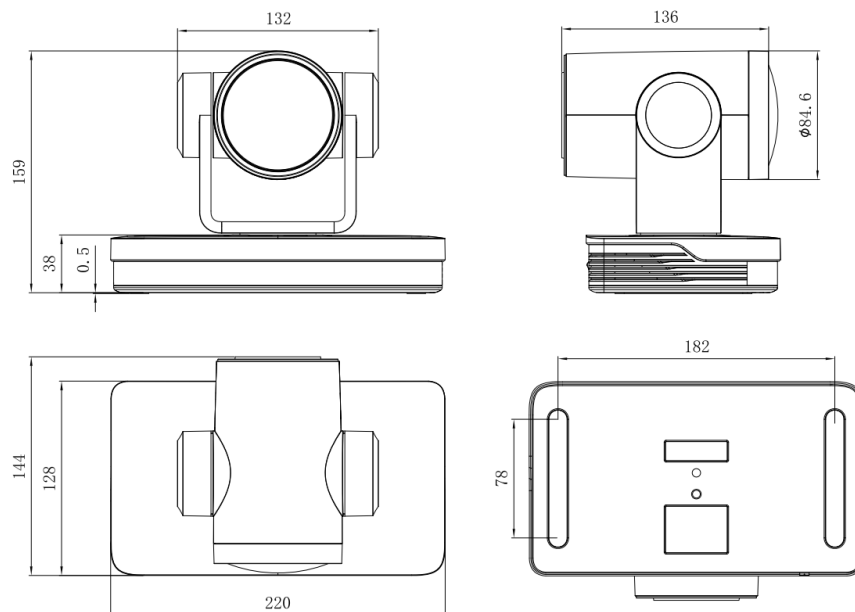

Figure 2.1 Product Dimension

2.1.2 Accessory

Please check below standard and optional accessories when unpacking the box.

Standard Accessory	Optional Accessory
Power adapter	Wireless Remote Control
IR Remote Control	Wall Mount
RS232 Cable	Ceiling Mount
User Manual	
USB3.0 Cable (only for model with USB3.0 output)	

2.2 Main Features

This series camera is a new UHD 4K camera, 12X optical zoom, 80.4° wide angle lens. It has perfect functions, superior performance and rich video output interfaces. Featuring with advanced ISP processing algorithms, offering vivid and high resolution video with a strong sense of depth and fantastic color rendition.

- **4K UHD Resolution:** 1/2.5inch high quality SONY CMOS sensor. Resolution is up to 4K with frame rate up to 60fps.
- **Dual Stream Output:** USB can support the main stream and sub stream output at the same time, and can meet the needs of near-end and far-end.
- **Optical Zoom Lens:** 12X optical zoom lens and 80.4° wide angle lens.
- **Rich and perfect interfaces:** Support HDMI, USB 3.0, LAN, and output 4K audio and video at the same time.
- **Leading Auto Focus Technology:** Fast, accurate and stable auto focusing technology.
- **Low Noise and High SNR:** Super high SNR image is achieved with low noise CMOS. Advanced 2D/3D noise reduction technology further reduces the noise while ensuring high image clarity.
- **Multiple Audio/Video Compression Standards:** LAN interface supports H.264/H.265 video compression, USB3.0 interface supports MJPG H264, YUY2, NV12, H265; support AAC, MP3 and G.711A audio compression, 8000, 16000, 32000, 44100, 48000 sampling frequency.
- **Multiple Network Protocol:** Support ONVIF, GB/T28181, RTSP, RTMP protocols; Support RTMP push mode, easy to be connected to streaming server (Wowza, FMS); Support RTP multicast mode; Support network full command VISCA control protocol.
- **Control Interface:** RS422 input (compatible with RS485), RS232 input/output, RS232 (cascade connection)
- **Multiple Control Protocol:** Support VISCA, PELCO-D, PELCO-P protocols; Support automatic identification protocols.
- **Multiple presets:** Up to 255 presets (10 presets via remote control).
- **Multiple Application:** Online-education, Lecture Capture, Webcasting, Video conferencing, Tele-medicine, Unified Communication, Emergency command and control systems, etc.

2.3 Technical Parameter

Camera Parameter	
Optical Zoom	12X f=3.85 mm ~ 43.06 mm ±5%
View Angle	Parallel: 7.59° (N) ~ 80.4° (W) Vertical: 4.6° (N) ~ 50.0° (W)
AV	F1.8 ~ F3.56±5%

Sensor	1/2.5inch SONY CMOS sensor
Effective Pixels	8.51M megapixel 16: 9
Video Format	<p>HDMI video format 4KP@60fps/4KP@50fps/4KP@30fps/4KP@25fps/1080P@60fps/1080P@50fps/1080I@60fps/1080I@50fps/1080P@30fps/1080P@25fps/720P@60fps/720P@50fps</p> <p>USB3.0 interface video format YUY2/NV12: 1920×1080@30/25fps/1280×720@30/25fps/960×540@30/25fps/640×360@30/25fps/ 640×480@30/25fps/320×176@30/25fps MJPEG/H.264/H.265: 3840×2160@30/25fps/1920×1080@30/25fps/1280×720@30/25fps/960×540@30/25fps/ /640×360@30/25fps/640×480@30/25fps/320×176@30/25fps</p> <p>USB3.0 is compatible with USB2.0 video format YUY2/NV12: 640×360@30/25fps/640×480@30/25fps/320×176@30/25fps MJPEG/H.264/H.265: 3840×2160@30/25fps/1920×1080@30/25fps/1280×720@30/25fps/960×540@30/25fp s/640×360@30/25fps/640×480@30/25fps/320×176@30/25fps</p>
Minimum Illumination	0.05Lux(F1.8, AGC ON)
DNR	2D & 3D DNR
White Balance	Auto / Manual/ One Push/ Specify color temperature
Focus	Auto/Manual/One Push Focus
Exposure Mode	Auto/Manual/Shutter priority/Aperture priority/brightness priority
Aperture	F1.8 ~ F11 CLOSE
Shutter Speed	1/25~1/10000
BLC	ON/OFF
WDR	OFF/ Dynamic level adjustment
Video Adjustment	Brightness, Color, Saturation, Contrast, Sharpness, B/W mode, Gamma curve
SNR	≥50dB

Input/output Interface	
Video Interfaces	HDMI, LAN(POE), USB3.0 (Type B compatible with USB2.0) , A-IN, RS232-IN, RS232-OUT, RS422 (compatible with RS485) , Rotary DIP switch, DC12V Power Supply, Power Switch
Video Compression Format	LAN Interface: H.264, H.265 USB 3.0 Interface: MJPG, H264, YUY2, NV12, H265
Audio Input Interface	Double track 3.5mm linear input
Audio Output Interface	HDMI, LAN, USB3.0
Audio Compression Format	AAC, MP3, G.711A
Network Interface	10M/100M/1000M Adaptive Ethernet port, support POE power supply, support audio and video output
Network Protocols	RTSP, RTMP, ONVIF, GB/T28181; Network VISCA control protocol; Support remote upgrade, reboot and reset
Control Interface	RS232-IN,RS232-OUT, RS422 compatible with RS485

Serial Communication protocol	VISCA/Pelco-D/Pelco-P; Baud Rate: 115200/38400/9600/4800/2400
USB Communication Protocol	UVC (Video), UAC (UAC)
Power Interface	HEC3800 outlet (DC12V)
Supply Adapter	AC110V~AC220V to DC12V/2.5A
Input Voltage	DC12V±10%
Input Current	<1A
Power Consumption	<12W

PTZ Parameter	
Pan Rotation	-110°~+110°
Tilt Rotation	-30°~+30°
Pan Control Speed	0.1°/s~100°/s
Tilt Control Speed	0.1°/s~70°/s
Preset Speed	Pan: 78.8°/s, Tilt: 31.7°/s
Preset Number	255 presets (10 presets via remote control)

Other Parameter	
Stored Temperature	-10°C~+60°C
Storage Humidity	20%~95%
Working Temperature	-10°C~+50°C
Working Humidity	20%~80%
Dimension	220(L)mm*144mm(W)*159mm(H)
Weight	1.7kg
Application	Indoor

Accessory	
Package	Power Supply, RS232 Control Cable, USB3.0 Cable(U3 model), IR Remote Control, User Manual, Warranty Card
Optional Accessories	Ceiling / Wall Mount (Extra Cost)

2.4 Interfaces Instruction

2.4.1 External Interface

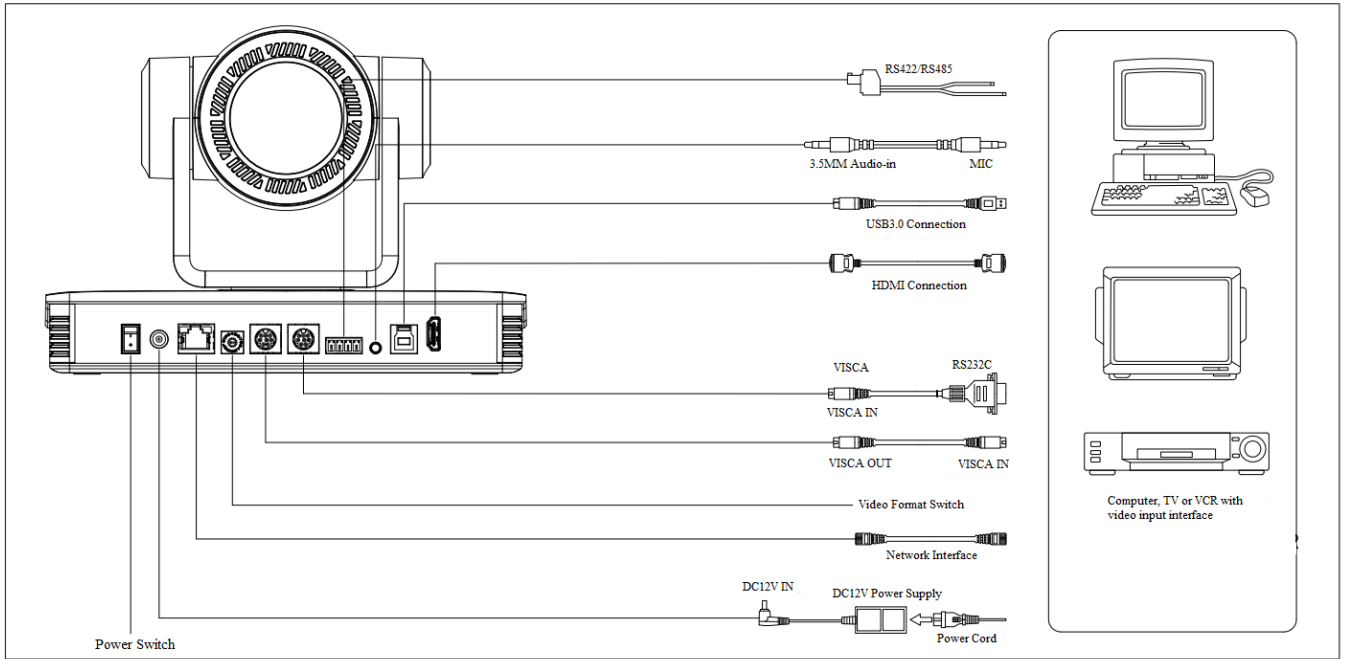
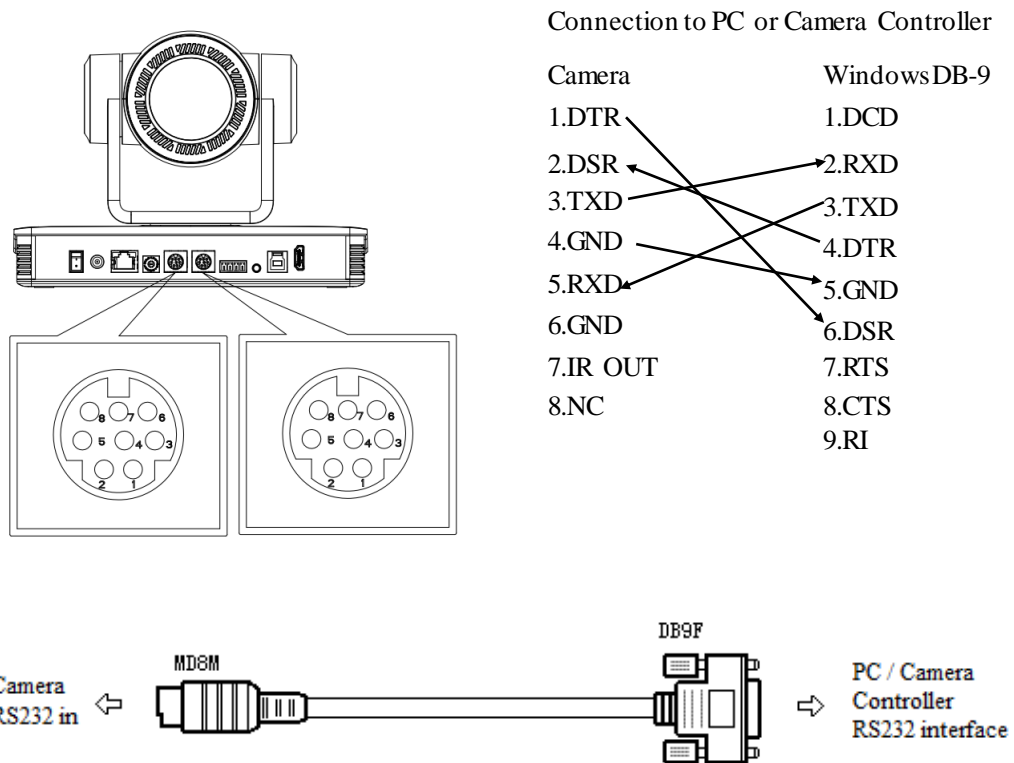

Figure 2.5 Wiring Diagram

2.4.2 RS-232 Interface

1) RS-232 Interface Definition



2) RS-232 Mini-DIN 8-pin Port Definition

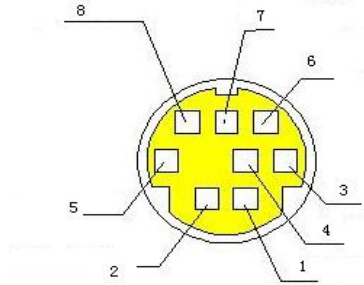

NO.	Port	Definition
1	DTR	Data Terminal Ready
2	DSR	Data Set Ready
3	TXD	Transmit Data
4	GND	Signal Ground
5	RXD	Receive Data
6	GND	Signal Ground
7	IR OUT	IR Commander Signal
8	NC	No Connection

3) RS232(DB9) Port Definition

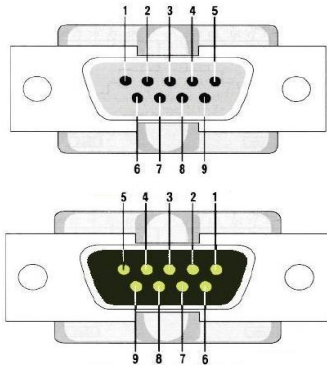

NO.	Port	Definition
1	DCD	Data Carrier Detect
2	RXD	Receive Data
3	TXD	Transmit Data
4	DTR	Data Terminal Ready
5	GND	System Ground
6	DSR	Data Set Ready
7	RTS	Request to Send
8	CTS	Clear to Send
9	RI	Ring Indicator

4) VISCA networking as shown below

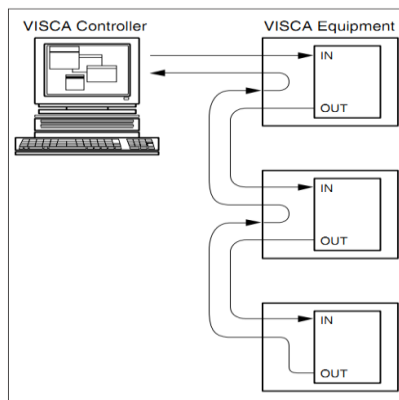

Camera cascade connection

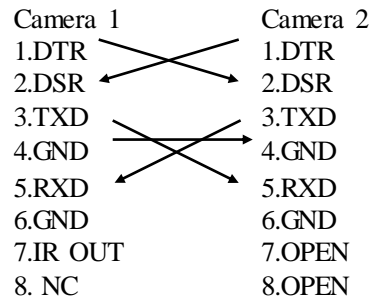

3. Application Instruction

3.1 Video Output

3.1.1 Power-On Initial Configuration

The remote control receiving indicator flashes after power on, the pan-tilt turns left to the lowest left to the lowest, and then turns to the HOME position (both the horizontal and vertical positions are in the middle), while the movement first shrinks and then stretches. When remote control receiving indicator stops flashing, the self-checking is completed. After power on and self-checking, the camera will automatically return to the preset 0 position if it's pre-set.

3.1.2 Video Output

Connect to the video output cable: the user can refer to Figure 1.1 product interfaces.

1) Network output: connect this product and your computer through network cable, then open the browser, enter the camera IP address (factory default 192.168.5.163) in the address bar, then to the login page and input a user name and password (factory default are "admin"), Finally enter the preview page, and the image comes out. (Note: If you forget your user name, password, IP address, you can manually restore the default by the RESET key at the bottom of the machine.)

2) HDMI output: Connect the monitor with the corresponding video output interface, then the monitor outputs image.

3) USB3.0 output: Connect the camera with the computer USB3.0 interface (blue), open the Device Manager to see whether there is an imaging device and whether the Universal Serial Bus controllers recognize the USB3.0 device. After properly identified, open the software, choose the imaging device, and then it will output the image.

4) USB3.0 compatible with USB2.0 output: Connect the camera with a computer USB2.0 interface (black), open the Device Manager to see whether there is an imaging device and whether the Universal Serial Bus controllers recognize USB3.0/USB2.0 device. After properly identified, open the software, choose the imaging device, and then it will output the image.

3.2 Remote Control

3.2.1 Match Code for Wireless Remote Control



One to One Code Matching:

Press the "set" and "*" keys combined for 3 seconds, LED indicator starts flashing. Camera receive the signal and power on, LED indicator will go off if code matching successfully.

The camera can be controlled by this wireless remote control only after one to one code pairing. Otherwise please clear the code matching of this remote control, or use other remote control to pair with the camera again.

If one to one code matching failed, the red LED light flashes for 20 seconds and then goes off, camera will stop code match and turn on sleep mode; Press any key to wake up the camera and re-match code.

Note: After code matching successfully, please select the camera address to control it.

Clear Code:

Press the "set" and "*" keys combined for 3 seconds, LED indicator starts flashing. Camera will power off and on, the LED indicator will go off if clear code successfully.

Sleep Mode and Wake Up:

Press any key to wake up the camera from sleep mode.

3.2.2 Keys Introduction for IR Remote Control

- 1) In this manual, "press the key" means a click rather than a long-press, and a special note will be given if a long-press for more than one second is required.
- 2) When a key-combination is required, do it in sequence. For example, "【*】+【#】+【F1】" means press "【*】" first and then press "【#】" and last press "【F1】".

1. Standby Key

The camera enters standby mode if long press 3s on standby key;
 Long press 3s again on the standby key, the camera will self-check again and return to HOME position (If preset 0 position is set, the camera will return to preset 0 position).

2. Camera Selection



Select the camera address to control.

3. Focus Control

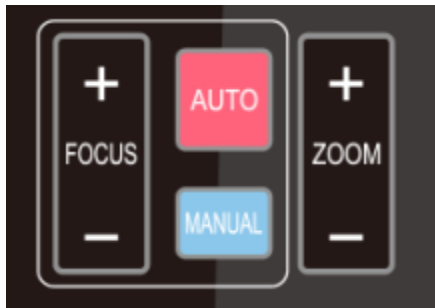

Auto: auto focus mode

Manual: manual focus mode

Focus + (near): Press **【FOCUS +】** key (Valid only in manual focus mode)

Focus - (far): Press **【FOCUS -】** key (Valid only in manual focus mode)

Press and hold the keys, the action of focus will keep continue and stop as soon as the key is released.

4. Zoom Control



ZOOM +: press **【ZOOM +】** key to zoom in

ZOOM - : press **【ZOOM -】** key to zoom out

Press and hold the keys, the action of focus will keep continue and stop as soon as the key is released.

5. Set and Clear Presets



Set Preset: press **【SET PRESET】** button, and then press the number key 0-9 to set preset positions.

Note: 10 presets via remote control.

Call Preset: Press a number key 0-9 directly to call a preset position.

Clear Preset: press **【CLEAR PRESET】** button, and then press the number key 0-9 to clear preset positions.

Note : press the **【#】** key three times continually to clear all presets.



6. Pan/Tilt Control



Up: press ▲ Down: press ▼
 Left: press ◀ Right: press ▶
 Back to middle position: press“ 【HOME】 ”

Press and hold the up/down/left/right key, the pan/tilt movements will keep running, from slow to fast, until it runs to the endpoint; stop as soon as the key is released.

7. Menu Setting



【MENU】 : Open / close the OSD menu
 【HOME】 : Camera lens back to the middle position;
 Confirm button; Enter next menu
 【↑】 【↓】 : Choose item
 【←】 【→】 : Modify values
 【BLC ON/OFF】 : Turn on or off the back light compensation

8. Camera Remote Control Address Setting

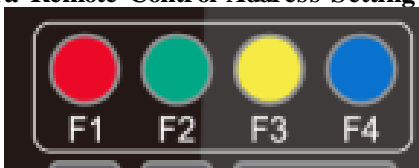

【*】 + 【#】 + 【F1】 :Camera Address No.1
 【*】 + 【#】 + 【F2】 :Camera Address No.2
 【*】 + 【#】 + 【F3】 :Camera Address No.3
 【*】 + 【#】 + 【F4】 :Camera Address No.4



9. Key Combination

- 1) **【#】 + 【#】 + 【#】** : Clear all presets
- 2) **【*】 + 【#】 + 【6】** : Restore factory defaults
- 3) **【*】 + 【#】 + 【3】** : Menu set to Chinese
- 4) **【*】 + 【#】 + 【4】** : Menu set to English
- 5) **【*】 + 【#】 + 【9】** : Flip switch
- 6) **【*】 + 【#】 + Auto**: Enter aging mode
- 7) **【#】 + 【*】 + Auto**: Exit aging mode
- 8) **【*】 + 【#】 + Manual**: Restore the default user name, password, and IP address
- 9) **【#】 + 【#】 + 【0】** : Switch the video format to 4KP60
- 10) **【#】 + 【#】 + 【1】** : Switch the video format to 4KP50
- 11) **【#】 + 【#】 + 【2】** : Switch the video format to 4KP30
- 12) **【#】 + 【#】 + 【3】** : Switch the video format to 4KP25
- 13) **【#】 + 【#】 + 【4】** : Switch the video format to 1080P60
- 14) **【#】 + 【#】 + 【5】** : Switch the video format to 1080P50
- 15) **【#】 + 【#】 + 【6】** : Switch the video format to 1080I60
- 16) **【#】 + 【#】 + 【7】** : Switch the video format to 1080I50
- 17) **【#】 + 【#】 + 【8】** : Switch the video format to 1080P30
- 18) **【#】 + 【#】 + 【9】** : Switch the video format to 1080P25

3.3 Menu Introduction

3.3.1 Main Menu

In normal working mode, press **【MENU】** key to display the menu, using scroll arrow to point at or highlight the selected items.

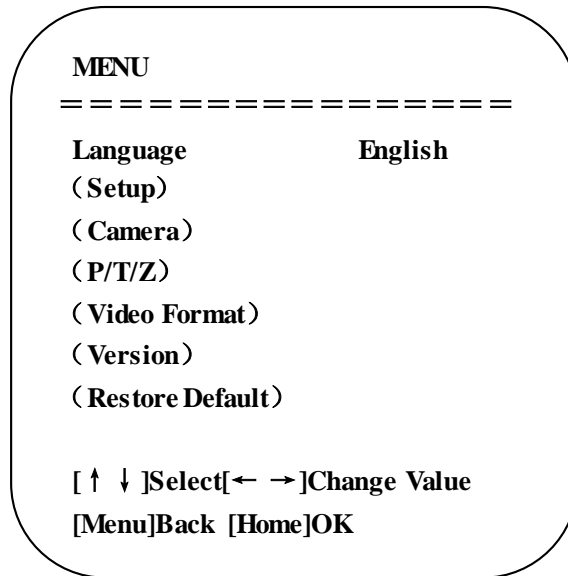

Language: Language setting, Chinese / English

Setup: System parameter setting

Camera: Camera parameter setting

P/T/Z: Enter into sub menu

Version: Enter into sub menu

Restore Default: Enter into reset setting, select YES or NO to confirm

[↑↓] **Select:** For selecting menu

[← →] **Change Value:** For modifying parameters

[MENU] **Back:** Press [Menu] to return

[Home] **OK:** Press [Home] to confirm

3.3.2 System Setting

Move the pointer to the (Setup) in the Main Menu, click the **【HOME】** key and enter into the (System Setting) as shown below,

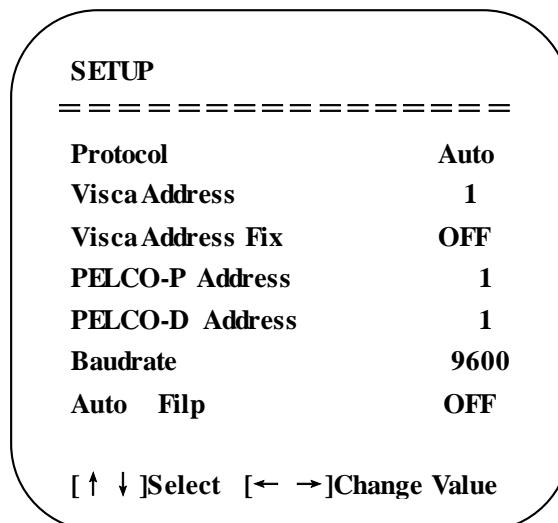

EXPOSURE	
=====	
Mode	Auto
EV	OFF
BLC	OFF
Flicker	50Hz
GLimit	6
DRC	关闭
[↑ ↓]Select [← →]Change Value	
[Menu]Back	

Mode: Auto, Manual, Shutter priority, Iris priority and Brightness priority.
EV: On/Off (only available in auto mode)
Compensation Level: -7~7 (only available in auto mode when EV is ON)
BLC: ON/OFF for options (only available in auto mode)
Dynamic Range: 1~8, close
Anti-Flicker: OFF/50Hz/60Hz for options (only available in Auto/Iris **priority**/Brightness **priority** modes)
Gain limit: 0~15(only available in Auto/ Iris **priority** /Brightness **priority** mode)
WDR: Off, 1~8
ShutterPriority:1/25,1/30,1/50,1/60,1/90,1/100,1/120,1/180,1/250,1/350,1/500,1/1000,1/2000,1/3000,1/4000,1/6000, 1/10000 (only available in Manual and Shutter priority mode)
IRIS Priority: OFF, F11.0, F9.6, F8.0, F6.8, F5.6, F4.8, F4.0, F3.4, F2.8, F2.4, F2.0, F1.8(only available in Manual and Iris priority mode)
Brightness:0~23 (only available in Brightness **priority** mode)

2) Color

Move the pointer to the (COLOR) in the Main Menu, click the **【HOME】** and enter the (COLOR sub menu) as follow,

COLOR	
=====	
WB Mode	Auto
RG Tuning	-10
BG Tuning	-10
Saturation	100%
Hue	7
AWB Sensitivity	High
[↑ ↓]Select [← →]Change Value	
[Menu]Back	

WB Mode: Auto, Manual, One Push, 3000K, 3500K, 4000K, 4500K, 5000K, 5500K, 6000K, 6500K, 7000K

Saturation: 60%,70%,80%,90%,100%,110%,120%,130%,140%,150%,160%,170%,180%,190% ,200%
Red fine-tuning: -10~10 (only available in automatic mode)
Blue fine-tunable: -10~10 (only available in automatic mode)
RED GAIN: 0~255(only available in Manualmode)
BLUE GAIN: 0~255(only available in Manualmode)
AWB Sensitivity: high/middle/low
Chroma: 0~14

3) Image

Move the pointer to the (IMAGE) in the Menu, click the **【HOME】** and enter into the (IMAGE sub menu) as follow,

IMAGE	
=====	
Brightness	7
Contrast	7
Sharpness	6
Flip-H	OFF
Flip-V	OFF
B&W-Mode	Color
Gamma	Default
DZoom	OFF
DCI	Close
Low-Light Mode	Close
[↑ ↓]Select [← →]Change Value	
[Menu]Back	

Brightness: 0~14
Contrast: 0~14
Sharpness: 0~15
Flip-H: On/Off
Flip-V: On/Off
B&W Mode: color, black/white
Gamma: Default/0.45/0.50/0.5/0.63
DCI: Dynamic Contrast: Off/1~8
Minimum Illumination: On/Off

4) Focus

Move the pointer to the (FOCUS) in the Menu, click the **【HOME】** and enter the (FOCUS) as follow,

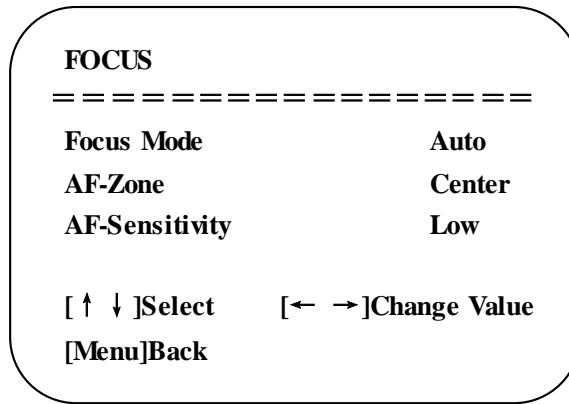

Focus Mode: Auto/manual
AF-Zone: Up/middle/down
AF-Sensitivity: High/middle/low

5) **Noise Reduction**

Move the pointer to the (NOISE REDUCTION) in the Menu, click the **【HOME】** and enter the (NOISE REDUCTION) as follow,

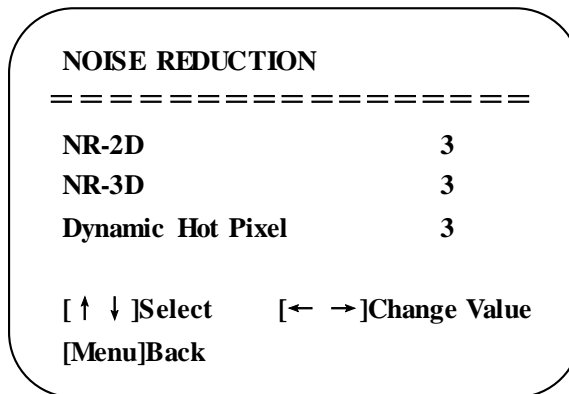

2D Noise Reduction: Auto, close, 1~7
3D Noise Reduction: Close, 1~8
Dynamic Hot Pixel: Close, 1~5

3.3.4 P/T/Z

Move the pointer to the (P/T/Z) in the Main Menu, click the **【HOME】** and enter the (P/T/Z) as follow,

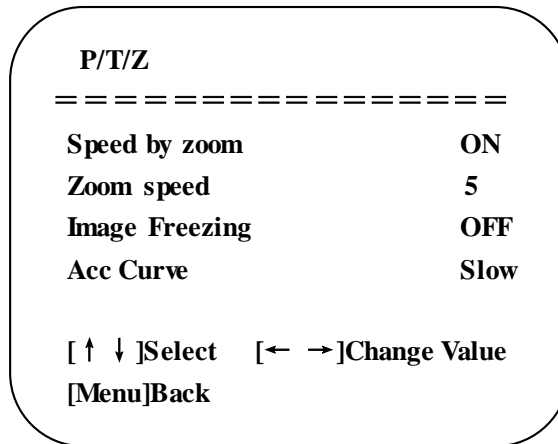

Depth of Field: Only effective for the remote controller, On/ Off;
 (When zooming in, the PT control speed by remoter will become slow)
Zoom Speed: Set the zoom speed for the remote controller, 1~8
Image Freezing: On/Off
Accelerating Curve: Fast/Slow

3.3.5 Video Format

Move the pointer to the (Video Format) in the Menu, click the **【HOME】** and enter the (Video Format) as follow,

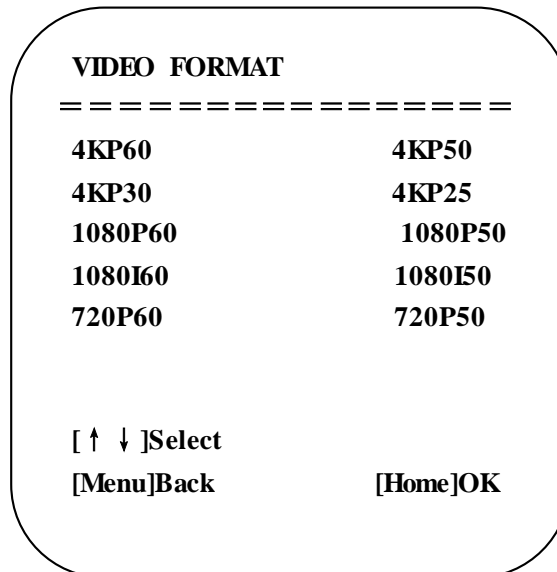

Note: Exit menu after modifying parameter to save it after powered off

3.3.6 Version

Move the pointer to the (VERSION) in the Main Menu, click the **【HOME】** and enter the (VERSION) as follow,

VERSION		
=====		
MCU Version	3.1.0	2019-11-23
Camera Version	1.0.0	2019-12-4
AF Version	1.0.0	2019-08-20

MCU Version: Display MCU version information
Camera Version: Display camera version information
AF Version: Display the focus version information

3.3.7 Restore Default

Move the pointer to the (RESTORE DEFAULT) in the Main Menu, click the **【HOME】** and enter the (RESTORE DEFAULT) as follow,

RESTORE DEFAULT	
=====	
Restore Default?	NO
[↑ ↓]Select	[← →]Change Value
[Menu]Back	[Home]OK

Restore default: YES/NO. Color style and video format cannot be restored to factory default

Note: If the address of former remoter is not 1 but another one from 2, 3, 4, the corresponding camera address will restore to 1 when all parameters or system parameters are restored. User should change the remoter address to be 1 (press No.1 according to the camera so to get normal operation)

4.Network Connection

4.1 Connecting Mode

Direct connection: Connect the camera via network cable to external Internet access of the PC
Internet connection mode: Connect the camera to Internet by Router or Switch and user can log in the device by browser.

Note: Please do not put the power and network cable in places where can be easily touched to prevent video quality lowered by unstable signal transmission due to poor contact of cables.

The computer must have the network segment where the camera IP address belong to. The device will not be accessible if without the segment. I.E. The camera default IP address is 192.168.5.163, then segment 5 must be added in the computer. Specific steps are as below:

Firstly open the window of Local Area Connection Properties on computer, select the “Internet protocol version 4(TCP/IPv4)” as shown by picture on the left. Double click or click the property “Internet” protocol version 4 (TCP/IPv4)to enter into the Internet Protocol Version 4(TCP/IPv4) Properties window, select “Advanced” to enter into the Advanced TCP/IP Setting and add IP and subnet mask in the IP browser as picture shown below. Click the “Confirm” to finish the adding of IP segment. User can add the corresponding network segment according to the revised IP address of the camera.

Note: The IP address to be added cannot be same with that of other computers or devices. The existence of this IP address needs to be verified before adding.

To verify whether the network segment has been successfully added, click the “Start” and select “Operation” to input cmd, then click OK and open DOS command window, type ping 192.168.5.26, press Enter key to display information shown below, which means network segment adding is succeeded.

```
C:\Users\qq214>ping 192.168.5.26

Pinging 192.168.5.26 with 32 bytes of data:
Reply from 192.168.5.26: bytes=32 time<1ms TTL=128
Reply from 192.168.5.26: bytes=32 time=1ms TTL=128
Reply from 192.168.5.26: bytes=32 time<1ms TTL=128
Reply from 192.168.5.26: bytes=32 time<1ms TTL=128

Ping statistics for 192.168.5.26:
    Packets: Sent = 4, Received = 4, Lost = 0 (0% loss),
    Approximate round trip times in milli-seconds:
        Minimum = 0ms, Maximum = 1ms, Average = 0ms

C:\Users\qq214>
```

User can also to verify network connection as steps above mentioned after the finish of camera self-check. If IP is default, open DOS command window and input 192.168.5.163, then press Enter key, It will show the message as below, which means network connection is normal.

```
C:\Users\qq214>ping 192.168.5.163

Pinging 192.168.5.163 with 32 bytes of data:
Reply from 192.168.5.163: bytes=32 time=2ms TTL=64
Reply from 192.168.5.163: bytes=32 time=1ms TTL=64
Reply from 192.168.5.163: bytes=32 time<1ms TTL=64
Reply from 192.168.5.163: bytes=32 time=4ms TTL=64

Ping statistics for 192.168.5.163:
    Packets: Sent = 4, Received = 4, Lost = 0 (0% loss),
    Approximate round trip times in milli-seconds:
        Minimum = 0ms, Maximum = 4ms, Average = 1ms

C:\Users\qq214>_
```

4.2 IE Login

4.2.1 Web Client

1) Web Client Login

Input the IP address 192.168.5.163 of the device in the address field of browser and click Enter button to enter into Web Client login page as below picture. User can login as administrator and normal user. If login as administrator (Default User name/Password: admin), users can preview, playback, configuration and cancel in the Web Client; If login in as normal user (Default User name/Password: user1 or user2), users can only preview, playback and logout, no option for configuration.

Note: Web access support browsers: IE, 360 browsers, and other conventional browsers.

Language Selection: click Chinese/English in the upper right corner of the login page to select the language type of the web interface.

2) Download/Install Plug in

When first using IE browser to access the web conferencing camera, the login page will appear “Playback plug-in is not installed, please download and install!” Click on this message, download and install MRWebXinstall.exe, according to information prompts.

After installing the plug, enter user name and password, click and Sign (initial default user name and password: "admin", users can change the user name and password on their own after entering) into the Web client management interface.

4.2.2 Preview

After successful login into the management interface, it enter the video preview interface. In the preview screen, users can control PTZ, zoom, focus, video capture, sound, focus, full screen and set the preset position, run, delete and other operations.

You can record the video and save it on SD Card when SD Card built-in. Video can be saved on the Computer at Local.

1) Login as administrator

User name, password the default admin

PTZ control can be carried out, zoom, focus, video capture, sound, zoom, full screen and set the preset position, run, and delete; you can preview, playback, configuration, log off.

2) Login as normal user

Default User name/password: user1 or user2

PTZ control can be carried out, zoom, focus, video capture, sound, zoom, full screen and set the preset position, run, and delete; you can preview, playback and logout.

NOTE: There are no configuration rights for normal user login.

4.2.3 Playback

1) Playback video files

First, please record, snapshot and save the file when previewing. Click "Playback" to enter recording file and picture files playback page, and then select the file "Video File" and click Search, and search out the video file, click Play to play the video file.

2) Playback picture files

First, please record, snapshot and save the file when previewing. Click "Playback" to enter recording file and picture files playback page, and then select the file "Image File" and click Search, and search out the video file, click Play to play the image file.

The default storage directory of local video/capture files is D:\MyIPCam\

4.2.4 Configuration

Click G to enter into the device parameters setting page

There are the following options: Local configuration, audio configuration, video configuration, network configuration, PTZ configuration, internet access configuration, system configuration, detailed description see the following table.

Menu	Explanation
Local configure	Including video preview mode, record video packing time ,record video storage route settings etc.
Audio configure	Including audio compressing format, sampling frequency, sampling precision, compressing code rate settings etc.
Video configure	Including video encoding, video parameters, character-overlapping, character size, video output setting etc.
Network configure	Including basic parameters, Ethernet, DNS, GB28181, wireless network setting etc.
System configure	Including equipment property, system time, user management, version update, reset, reboot device settings etc.

1) Local configuration

Video Preview Mode: user can choose real-time priority or fluency priority: The delay will be small when under real time priority mode and fluency will be good when under fluency priority mode. Setting based on the user need (Default value: real time normal (2), real time best (1), fluency normal (3), fluency good (4) and fluency best (5))

Recording packing time (minute): Set recording video packing time (default is 10, range from 1~120 minutes)

Recording file packaging format type: set the video file packaging format type (default MP4, TS optional)

Recording/Snapshot file storage route: Set local recording video/snapshot file storage route. (Default D:\MyIPCam\)

Click the **Save** button to make settings effective.

2) Audio Configuration

Switch: Choose to enable the audio or not.

Compressing Format: Set audio compressing format and the device will reboot automatically after change (default MP3, AAC, G711A optional)

Sampling Frequency: Set sampling frequency and the device will reboot automatically after change (default

44100, 8000, 16000, 32000 and 48000 optional, G711A default 8000)

Sampling Precision: Set sampling precision (default 16bits)

Compressing Code Rate: Set audio compressing code rate (default 64bits, 32, 48, 96, 128bits optional)

Input Volume: Set the input volume (default 2, 1-10 optional)

Click "Save", it will remind "Enable has changed. Restart the device to take effect after the success of the save.", then please reboot the camera to make new setting effect.

4.2.5 Video Configuration

1) Video Encoding

Code stream: Stream: Different video output mode setting, use different streams.(Main stream, secondary stream)

Compression Format: Set the video compression format, save and reboot to take it effect (main / secondary stream default: H.264, H.265 optional)

Profile: Set Profile mode (default HP, BP, MP optional)

Video Size: Set video image resolution, save and reboot to take it effect (main stream default 1920*1080 3840*2160, 2592*1944, 2304*1296, 1920*1080, 1280*720 optional; default secondary stream 320*180, 640*360, 320*240, 640*480, 320*180, 1280*720 optional)

Stream Rate control: Set rate control mode, save and reboot to take it effect (main / secondary stream default variable bit rate, fixed rate is for option).

Image Quality: Set the image quality, image quality can be changed only when rate control is variable bit rate, (main stream default is better, secondary stream default is not good, there are best, better, good, bad, worse, worst for options).

Rate (Kb / s): Set the video bit rate (main stream default 8192b/s, 64-40960Kb/s optional; secondary stream default 512Kb/s, 64-40960Kb/s optional).

Frame rate (F/S): Set the video frame rate (main/ secondary stream default 25F/S, main stream 5-60F/S optional, secondary stream 5-30F/S optional).

Key frame interval: Set the key frame interval (main / secondary stream default 100, main stream 1-300F optional, secondary stream 1-150F optional).

Stream Name: When streaming via rtsp or rtmp, user can modify stream name. Main Stream (live/av0), secondary stream (live/av1)

Click the "Save" button to display the "saved successfully" message, then settings take effect.

2) Stream Release

Switch: To turn on/off the main / secondary stream.

Protocol: primary / secondary stream applies RTMP protocol.

Host Port: server port number (default 1935, 0-65535 optional)

Host Address: server IP addresses (default 192.168.5.11)

Stream Name: choose a different stream name (live / av0, live / av1 optional).

User: Set the user name.

Password: Set the password.

Click on the "Save" button to display the "Save successful" message, then settings take effect.

Method of obtaining RTSP: RTSP: // device IP address:554 / live / av0 (av0 main stream; av1 secondary stream)

2) Stream Release

Switch: To turn on/off the main / secondary stream.

Protocol: primary / secondary stream applies RTMP protocol.

Host Port: server port number (default 1935, 0-65535 optional)

Host Address: server IP addresses (default 192.168.5.11)

Stream Name: choose a different stream name (live / av0, live / av1 optional).

User: Set the user name.

Password: Set the password.

Click on the "Save" button to display the "Save successful" message, then settings take effect.

Method of obtaining RTSP: RTSP: // device IP address:554 / live / av0 (av0 mainstream; av1 secondary stream)

3) RTP Broadcasting

Main/Sub Stream: On/off

Protocol: RTP or TS

Address: Default 224.1.2.3. It can be edited.

Port: Main Stream Default Port: 4000, Sub Stream Default Port: 4002

Visit: Address comes up after setting. Eg ; rtp://224.1.2.3:4000; udp://@224.1.2.3:4000

3)Video Parameters

a. **Focus: Focus mode, focus range, focus sensitivity can be set.**

Focus Mode: set the focus mode (the default auto, manual optional)

Focus range: set the focus range (the default middle, the upper and lower optional)

Focus Sensitivity: Set the focus sensitivity (default is low, high, medium optional)

b. **Exposure: Exposure mode, exposure compensation, back light compensation, anti-flicker, gain limit, wide dynamic, shutter speed, aperture value and brightness can be set.**

Exposure Mode: Set the exposure mode (the default automatic, manual, shutter priority, aperture priority, Brightness priority optional)

Exposure compensation: Exposure compensation setting is active when it is auto status (default is off).

Exposure compensation value: Set the exposure compensation value, valid when it is set for auto (default 0, -7 to 7 optional).

BLC: Set back light compensation, valid when it is auto status (default is off).

Anti-flicker: Set up anti-flicker mode, valid when status of automatic, aperture or brightness priority (default 50Hz, closed, 60Hz optional).

Gain limit: set the gain limits, auto, active when it is status of aperture or brightness priority (default 4, 0-15 optional).

Dynamic range: Set the dynamic range (default 4, 1-8 optional).

Shutter speed: Active when it is status of manual or shutter-priority (default 1/100,

1/25,1/30,1/50,1/60,1/90,1/100,1/120,1/180,1/250,1/350,1/500,1/1000,1/2000,1/3000,1/4000,1/6000,1/10000 optional).

Aperture value: Set the aperture value, active when it is status of manual or aperture-priority (default F1.8, closed F11, F9.6, F8.0, F6.8, F5.6, F4.8, F4.0, F3.4, F2.8, F2.4, F2.0, F1.8 optional).

Brightness: Set the brightness value, active when it is a state of brightness priority (default 7, 0-23 optional).

c. **Color: White balance, saturation, color, white balance, sensitivity, color temperature, gain red and blue gain can be set.**

White balance modes: Set the white balance mode (the default automatic, 3000K, 3500K, 4000K, 4500K, 5000K, 5500K, 6500K, 7000K manual, One-push optional).

Note: Click the "Correction" button when selected the One-push white balance mode.

Red fine-tuning: default -10~10 (only available in automatic mode)

Blue fine-tunable: default -10~10 (only available in automatic mode)

Saturation: Set the saturation (default 60%, 70%, 80%, 90%, 100%, 110%, 120%, 130%, 140%, 150%, 160%, 170%, 180%, 190%, 200% optional).

Auto white balance Sensitivity: Sensitivity Auto white balance settings (default is low, high, medium optional).

Chroma: Set the chroma (default 7, 0-14 optional).

White balance sensitivity: Set the white balance sensitivity (Default setting: High, with low, middle for options)

Red Gain: Set the red gain, effective when it is manual (default 145, 0-255 optional).

Blue Gain: Sets the Blue gain, effective when it is manual (default 56, 0-255 optional).

d. **Image: Brightness, contrast, sharpness, black and white mode, the gamma curve, Horizontal Flip and Vertical Flip can be set.**

Brightness: Set the brightness (default 7, 0-14 optional).

Contrast: set the contrast (default 7, 0-14 optional).

Sharpness: Set the sharpness value (default 6, 0-15 optional).

Black and white mode: Set black and white mode (default color, black/white optional).

Gamma: Gamma value setting (default, 0.45, 0.50, 0.55, 0.63 optional).
Dynamic Contrast: set the dynamic contrast (default off, 1~8 optional)
Flip Horizontal: Set Flip Horizontal (default Off, On optional).
Flip Vertical: Set vertical flip (default Off, On optional).
Electronic zoom: set the electronic zoom (default Off, On optional)

e. **Noise Reduction: 2D noise reduction, 3D noise reduction and dynamic dead pixel correction available.**
2D Noise Reduction: Set 2D noise reduction level (default 3, Auto, 1-7 and Off optional).
3D Noise Reduction: Set 3D noise reduction level (default 5, 1-8 and Off optional).
Dynamic dead pixel correction: Set Dynamic dead pixel correction (default Off, 1-5 optional).

Note: Click "Refresh" to make revision of any video parameters of a, b, c, d, e effective.

4) Character-Overlapping

Display date and time: Set whether to display the time and date (default display).
Display Title: Set whether to display the title (default display).
Font Color of Time: Set font color of time and date (default white, black, yellow, red, and blue optional).
Font Color of Title: Set font color of title (default white, black, yellow, red, and blue optional).
Moving characters: Set the display position of moving date, time and title, click on the "up, down, left, right" buttons to move the corresponding character position.
Title Content: Set title content (default CAMERA1).
Time Content: Set time content (default 1970/01/10 05:36:00)
Click on the "Save" button and display the "Save successful" message, then valid

5) Character Size

Main stream character size: Set the character size of the display, the device will restart automatically after changed and saved (default 48, 28-200 optional)
Secondary stream character size: Set the character size of the display, the device will restart automatically after changed and saved (default 48, 28-200 optional)
Click on the "Save" button to display "Parameter saved successfully" message, set to take effect

6) Video output

Output format: 3840x2160P60, 3840x2160P50, 3840x2160P30, 3840x2160P25
1080P60, 1080P50, 1080P30, 1080P25, 1080I60, 1080I50, 720P60, 720P50
Click on the "Save" button, it will be valid when display "Save successful".

4.2.6 Network Configuration

1) Network port

Data port: set the data port, the device will restart automatically after changed (default 3000, 0-65535 optional)
Web Port: Set Web port, the device will restart automatically after changed (default is 80, 0-65535 is optional)
Onvif Port: Set Onvif port, the device will restart automatically after changed (default 2000, 0-65535 optional)
Soap Port: Set Soap port (default 1936, 0-65535 optional)
RTMP Port: Set RTMP port (default 1935, 0-65535 optional)
RTSP Port: Set RTSP port, the device will restart automatically after changed (default 554, 0-65535 optional).
ViscaPort: Set Visca port, the device will restart automatically after changed (default 3001, 0-65535 optional).
Click on the "Save" button, it will be valid when display "Save successful".

RTSP Obtaining method: rtsp:// device IP address:554 / live / av0 (av0 main stream; av1 secondary stream)

RTMP Obtaining method: rtmp:// device IP address: 1935 / live / av0 (av0 main stream; av1 secondary stream)

2) Ethernet parameters

DHCP: Enable or disable obtain IP automatically can be set. Save changes and reboot the device to takes effect (default: OFF)

IP Address: Set the IP address, save changes and reboot the device to takes effect (default 192.168.5.163). Note: This IP address is the same with the one used to login Web page.

Subnet Mask: Set the subnet mask (default 255.255.5.0).

Default Gateway: Set the default gateway (default 0.0.0.0).

Physical Address: Set the physical address (the parameter is read-only but can not be modified).

Click on the "Save" button, it will be valid when display "Save successful". (Note: To prevent IP conflicts When modify)

3) DNS parameters

Preferred DNS server: set the preferred DNS server. (Default 0.0.0.0).

Alternate DNS server: Alternate DNS server settings. (Default 0.0.0.0).

Click on the "Save" button, it will be valid when display "Save successful".

4) GB28181

Switch: set whether open GB28181, can check

Time Synchronization: whether synchronization time is set, you can check

Stream Type: stream type setting (the default main stream, secondary stream optional)

Sign effective time (in seconds): 3600 Range 5-65535

Heartbeat time (seconds): 60 Range 1-65535

Register ID: 3402000001320000001

Register User name: IPC

Register Password: 12345678

Equipment ownership: Users can add their own

Administrative regions: Users can add their own

Alarm Zone: Users can add their own

Equipment installation address: Users can add their own

Local SIP Port: 5060 Range 0-65535

GB28181 Server Address: IP address of the computer

Server SIP Port: 5060 Range 0-65535

Server ID: 3402000000200000001

Click on the "Save" button, it will be valid when display "Save successful".

4.2.7 System Configuration

1) Device Properties

Device Name: Set the device name (the default Camera1, user can add their own).

Device ID: Set the device ID (default 1, Read-Only).

System Language: Set the system language (default Simplified Chinese, English optional). Need to re-login after modify and save the setting.

Click on the "Save" button, it will be valid when display "Save successful".

2) System Time

Date Format: Set the date format (YYYY-MM-DD default That year - month - day, MM-DD-YYYY namely Month - Day - Year, DD-MM-YYYY date - month - year Optional).

Date separator: set the date separator (default '/', ':', '-' Optional).

Time Zone: Set the time zone (default East eight districts, other time zones optional).

Time Type: Set the time types (default 24 hours, optional 12 hours).

Time setting: Set time mode (to choose the computer time synchronization, NTP server time synchronization, or set manually).

Computer Time: Set the computer synchronization valid.

Update interval: Set the NTP server automatic updated time interval. Valid after setting NTP server synchronization (default one day, 2-10 days Optional).

NTP server address or domain name: Set NTP server address or domain name (default time.nits.gov). Valid after setting NTP server synchronization.

NTP Server Port: Sets the NTP server port (default 123). Valid after setting NTP server synchronization. Set the time manually, Effective when set manually.

Click on the "Save" button, it will be valid when display "Save successful".

3) User Management

Select users: Set the user type (the default administrator, Common User 1, Common User 2 optional)

User name: set the user name (Select User Administrator default admin; select a common user1 default user1; to select a common user 2 default user2; user can modify their own)

Password: Set a password (Select User Administrator default admin; select a common user1 default user1; to select a common user 2 default user2; user can modify their own).

Password confirmation: Confirm the input passwords are the same or not.

Click on the "Save" button to display the "Save successfully" message, then the set is to take effect.

Please note the case-sensitivity of the user name and password.

If login page by a common user's name and password, one does not have configuration privileges but can only operate to preview, playback, logout.

4) Version upgrade

Users only read the version information above which is consistent with the menu version but can not modify.

Different types of the machine has different information.

Update file: Click "Browse ..." installation, to select the upgrade file in the pop-up window.

Click on the "Upgrade" button, the upgrade dialog will appear, the device will reboot automatically after update successfully.

(Note: Make sure the power and network is keeping connected during the process, or the upgrade will fail)

Note: After the version upgrade is complete, you need to restore factory defaults; a. through web to restore the factory default configuration; b. through the recovery menu; c. remote control shortcut * # 6;

Choose one of the above three ways. The IP account and password of mode a are also restored to default.

5) Restore factory setting

Click on pop-up "Restore Factory Defaults" button and choose "yes" or "no", then the device will restart automatically and restore factory setting.

6) Reboot

Click on the pop-up "Reboot" button and choose "yes" or "no", then the device will restart automatically.

4.2.8 Logout

Point "Logout" pop-up "Confirmation" dialog; select "Yes" or "No", choose "Yes" to exit the current page and return to the user login interface again.

5. Serial Port Communication and Control

The camera could be controlled through RS232/RS485 interface; RS232C serial parameter are as follows:
 Baud rate: 2400/4800/9600/115200 bits / sec; Start bit: 1; data bits:8; Stop bit: 1; Parity: None.

After power on, the camera first goes left, then back to the middle position. Self-test is finished after the zoom moved to the farthest and then back to the nearest position. If the camera saved 0 preset before, it will be back to that position after initialization. At this point, the user can control the camera by the serial commands.

5.1 VISCA Protocol List

5.1.1 VISCA Protocol Return Command

Ack/Completion Message		
	Command packet	Note
ACK	z0 41 FF	Returned when the command is accepted.
Completion	z0 51 FF	Returned when the command has been executed.

z = camera address + 8

Error Messages		
	Command packet	Note
Syntax Error	z0 60 02 FF	Returned when the command format is different or when a command with illegal command parameters is accepted
Command Not Executable	z0 61 41 FF	Returned when a command cannot be executed due to current conditions. For example, when commands controlling the focus manually are received during auto focus.

5.1.2 VISCA Protocol Control Command

Command	Function	Command packet	Note
AddressSet	Broadcast	88 30 0p FF	p: Address setting
IF_Clear	Broadcast	88 01 00 01 FF	I/F Clear
CommandCancel		8x 21 FF	
CAM_Power	On	8x 01 04 00 02 FF	Power ON/OFF
	Off	8x 01 04 00 03 FF	
CAM_Zoom	Stop	8x 01 04 07 00 FF	p = 0(low) - F(high) pqrs: Zoom Position
	Tele(Standard)	8x 01 04 07 02 FF	
	Wide(Standard)	8x 01 04 07 03 FF	
	Tele(Variable)	8x 01 04 07 2p FF	
	Wide(Variable)	8x 01 04 07 3p FF	
	Direct	8x 01 04 47 0p 0q 0r 0s FF	
CAM_Focus	Stop	8x 01 04 08 00 FF	p = 0(low) - F(high) pqrs: Focus Position
	Far(Standard)	8x 01 04 08 02 FF	
	Near(Standard)	8x 01 04 08 03 FF	
	Far(Variable)	8x 01 04 08 2p FF	
	Near (Variable)	8x 01 04 08 3p FF	
	Direct	8x 01 04 48 0p 0q 0r 0s FF	
	Auto Focus	8x 01 04 38 02 FF	
	Manual Focus	8x 01 04 38 03 FF	
One Push mode	8x 01 04 38 04 FF		
CAM_Zoom Focus	Direct	8x 01 04 47 0p 0q 0r 0s 0t 0u 0v 0w FF	pqrs: Zoom Position tuvw: Focus Position

Command	Function	Command packet	Note
CAM_WB	Auto	8x 01 04 35 00 FF	
	3000K	8x 01 04 35 01 FF	
	4000k	8x 01 04 35 02 FF	
	One Push mode	8x 01 04 35 03 FF	
	5000k	8x 01 04 35 04 FF	
	Manual	8x 01 04 35 05 FF	
	6500k	8x 01 04 35 06 FF	
	3500K	8x 01 04 35 07 FF	
	4500K	8x 01 04 35 08 FF	
	5500K	8x 01 04 35 09 FF	
	6000K	8x 01 04 35 0A FF	
7000K	8x 01 04 35 0B FF		
CAM_RGain	Reset	8x 01 04 03 00 FF	Manual Control of R Gain
	Up	8x 01 04 03 02 FF	
	Down	8x 01 04 03 03 FF	
	Direct	8x 01 04 43 00 00 0p 0q FF	pq: R Gain
CAM_Bgain	Reset	8x 01 04 04 00 FF	Manual Control of B Gain
	Up	8x 01 04 04 02 FF	
	Down	8x 01 04 04 03 FF	
	Direct	8x 01 04 44 00 00 0p 0q FF	pq: B Gain
CAM_AE	Full Auto	8x 01 04 39 00 FF	Automatic Exposure mode
	Manual	8x 01 04 39 03 FF	Manual Control mode
	Shutter priority	8x 01 04 39 0A FF	Shutter Priority Automatic Exposure mode
	Iris priority	8x 01 04 39 0B FF	Iris Priority Automatic Exposure mode
	Bright	8x 01 04 39 0D FF	Bright mode
CAM_Shutter	Reset	8x 01 04 0A 00 FF	Shutter Setting
	Up	8x 01 04 0A 02 FF	
	Down	8x 01 04 0A 03 FF	
	Direct	8x 01 04 4A 00 00 0p 0q FF	pq: Shutter Position
CAM_Iris	Reset	8x 01 04 0B 00 FF	Iris Setting
	Up	8x 01 04 0B 02 FF	
	Down	8x 01 04 0B 03 FF	
	Direct	8x 01 04 4B 00 00 0p 0q FF	pq: Iris Position
CAM_Gain Limit	Gain Limit	8x 01 04 2C 0p FF	p: Gain Positon
CAM_Bright	Reset	8x 01 04 0D 00 FF	Bright Setting
	Up	8x 01 04 0D 02 FF	
	Down	8x 01 04 0D 03 FF	
	Direct	8x 01 04 4D 00 00 0p 0q FF	pq: Bright Positon
CAM_ExpComp	On	8x 01 04 3E 02 FF	Exposure Compensation ON/OFF
	Off	8x 01 04 3E 03 FF	
	Reset	8x 01 04 0E 00 FF	Exposure Compensation Amount Setting
	Up	8x 01 04 0E 02 FF	
	Down	8x 01 04 0E 03 FF	
	Direct	8x 01 04 4E 00 00 0p 0q FF	pq: ExpComp Position
CAM_Back Light	On	8x 01 04 33 02 FF	Back Light Compensation
	Off	8x 01 04 33 03 FF	

Command	Function	Command packet	Note
CAM_WDRStrength	Reset	8x 01 04 21 00 FF	WDR Level Setting
	Up	8x 01 04 21 02 FF	
	Down	8x 01 04 21 03 FF	
	Direct	8x 01 04 51 00 00 00 0p FF	p: WDR Level Positon
CAM_NR (2D)		8x 01 04 53 0p FF	P=0-7 0:OFF
CAM_NR (3D)		8x 01 04 54 0p FF	P=0-8 0:OFF
CAM_Gamma		8x 01 04 5B 0p FF	p = 0 - 4 0: Default 1: 0.45 2: 0.50 3: 0.55 4: 0.63
CAM_Flicker	OFF	8x 01 04 23 00 FF	OFF
	50HZ	8x 01 04 23 01 FF	50HZ
	60HZ	8x 01 04 23 02 FF	60HZ
CAM_Aperture	Reset	8x 01 04 02 00 FF	Aperture Control
	Up	8x 01 04 02 02 FF	
	Down	8x 01 04 02 03 FF	
	Direct	8x 01 04 42 00 00 0p 0q FF	pq: Aperture Gain
CAM_Memory	Reset	8x 01 04 3F 00 pq FF	pq: Memory Number(=0 to 254) Corresponds to 0 to 9 on the Remote Commander
	Set	8x 01 04 3F 01 pq FF	
	Recall	8x 01 04 3F 02 pq FF	
CAM_LR_Reverse	On	8x 01 04 61 02 FF	Image Flip Horizontal ON/OFF
	Off	8x 01 04 61 03 FF	
CAM_PictureFlip	On	8x 01 04 66 02 FF	Image Flip Vertical ON/OFF
	Off	8x 01 04 66 03 FF	
CAM_ColorSaturation	Direct	8x 01 04 49 00 00 00 0p FF	P=0-E 0:60% 1:70% 2:80% 3:90% 4:100% 5:110% 6:120% 7:130% 8:140% 9:150% 10:160% 11:160% 12:180% 13:190% 14:200%
CAM_IDWrite		8x 01 04 22 0p 0q 0r 0s FF	pqrs: Camera ID (=0000 to FFFF)
SYS_Menu	ON	8x 01 04 06 06 02 FF	Turn on the menu screen
	OFF	8x 01 04 06 06 03 FF	Turn off the menu screen
IR_Receive	ON	8x 01 06 08 02 FF	IR(remote commander)receive On/Off
	OFF	8x 01 06 08 03 FF	
IR_ReceiveReturn	On	8x 01 7D 01 03 00 00 FF	IR(remote commander)receive message via the VISCA communication ON/OFF
	Off	8x 01 7D 01 13 00 00 FF	
CAM_SettingReset	Reset	8x 01 04 A0 10 FF	Reset Factory Setting
CAM_Brightness	Direct	8x 01 04 A1 00 00 0p 0q FF	pq: Brightness Position
CAM_Contrast	Direct	8x 01 04 A2 00 00 0p 0q FF	pq: Contrast Position
CAM_Flip	OFF	8x 01 04 A4 00 FF	Single Command For Video Flip
	Flip-H	8x 01 04 A4 01 FF	
	Flip-V	8x 01 04 A4 02 FF	
	Flip-HV	8x 01 04 A4 03 FF	
CAM_VideoSystem	Set camera video system	8x 01 06 35 00 0p FF	P: 0~E Video format 0:1080P60 8:720P30 1:1080P50 9:720P25 2:1080i60 A: 1080P59.94 3:1080i50 B: 1080i59.94 4:720P60 C: 720P59.94 5:720P50 D: 1080P29.97 6:1080P30 E: 720P29.97

Command	Function	Command packet	Note
			7:1080P25
Pan_tiltDrive	Up	8x 01 06 01 VV WW 03 01 FF	VV: Pan speed 0x01 (low speed) to 0x18 (high speed) WW: Tilt speed 0x01 (low speed) to 0x14 (high speed) YYYY: Pan Position ZZZZ: Tilt Position
	Down	8x 01 06 01 VV WW 03 02 FF	
	Left	8x 01 06 01 VV WW 01 03 FF	
	Right	8x 01 06 01 VV WW 02 03 FF	
	Upleft	8x 01 06 01 VV WW 01 01 FF	
	Upright	8x 01 06 01 VV WW 02 01 FF	
	DownLeft	8x 01 06 01 VV WW 01 02 FF	
	DownRight	8x 01 06 01 VV WW 02 02 FF	
	Stop	8x 01 06 01 VV WW 03 03 FF	
	AbsolutePosition	8x 01 06 02 VV WW 0Y 0Y 0Y 0Y 0Z 0Z 0Z 0Z FF	
	RelativePosition	8x 01 06 03 VV WW 0Y 0Y 0Y 0Y 0Z 0Z 0Z 0Z FF	
	Home	8x 01 06 04 FF	
Reset	8x 01 06 05 FF		
Pan-tiltLimitSet	Set	8x 01 06 07 00 0W 0Y 0Y 0Y 0Y 0Z 0Z 0Z 0Z FF	W:1 UpRight 0:DownLeft YYYY: Pan Limit Position(TBD) ZZZZ: Tilt Limit Position(TBD)
	Clear	8x 01 06 07 01 0W 07 0F 0F 0F 07 0F 0F 0F FF	

5.1.3 VISCA Protocol Inquiry Command

Command	Command Packet	Return Packet	Note
CAM_PowerInq	8x 09 04 00 FF	y0 50 02 FF	On
		y0 50 03 FF	Off(Standby)
CAM_ZoomPosInq	8x 09 04 47 FF	y0 50 0p 0q 0r 0s FF	pqrs: Zoom Position
CAM_FocusAFModeInq	8x 09 04 38 FF	y0 50 02 FF	Auto Focus
		y0 50 03 FF	Manual Focus
		y0 50 04 FF	One Push mode
CAM_FocusPosInq	8x 09 04 48 FF	y0 50 0p 0q 0r 0s FF	pqrs: Focus Position
CAM_WBModeInq	8x 09 04 35 FF	y0 50 00 FF	Auto
		y0 50 01 FF	3000K
		y0 50 02 FF	4000K
		y0 50 03 FF	One Push Mode
		y0 50 04 FF	5000K
		y0 50 05 FF	Manual
		y0 50 06 FF	6500K
		y0 50 07 FF	6500K
		y0 50 08 FF	3500K
		y0 50 09 FF	4500K
		y0 50 0A FF	5500K
		y0 50 0B FF	6000K
CAM_RGainInq	8x 09 04 43 FF	y0 50 0B FF	7000K
CAM_BGainInq	8x 09 04 44 FF	y0 50 00 00 0p 0q FF	pq: B Gain
CAM_AEModeInq	8x 09 04 39 FF	y0 50 00 FF	Full Auto
		y0 50 03 FF	Manual
		y0 50 0A FF	Shutter priority
		y0 50 0B FF	Iris priority
		y0 50 0D FF	Bright
CAM_ShutterPosInq	8x 09 04 4A FF	y0 50 00 00 0p 0q FF	pq: Shutter Position
CAM_IrisPosInq	8x 09 04 4B FF	y0 50 00 00 0p 0q FF	pq: Iris Position
CAM_Gain LimitInq	8x 09 04 2C FF	y0 50 0p FF	p: Gain Position
CAM_BrightPosInq	8x 09 04 4D FF	y0 50 00 00 0p 0q FF	pq: Bright Position
CAM_ExpCompModeInq	8x 09 04 3E FF	y0 50 02 FF	On
		y0 50 03 FF	Off
CAM_ExpCompPosInq	8x 09 04 4E FF	y0 50 00 00 0p 0q FF	pq: ExpComp Position
CAM_BacklightModeInq	8x 09 04 33 FF	y0 50 02 FF	On

		y0 50 03 FF	Off
CAM_WDRStrengthInq	8x 09 04 51 FF	y0 50 00 00 00 0p FF	p: WDR Strength
CAM_NRLevel(2D) Inq	8x 09 04 53 FF	y0 50 0p FF	P: 2DNRLLevel
CAM_NRLevel(3D) Inq	8x 09 04 54 FF	y0 50 0p FF	P:3D NRLevel
CAM_FlickerModeInq	8x 09 04 55 FF	y0 50 0p FF	p: Flicker Settings(0: OFF, 1: 50Hz, 2:60Hz)
CAM_ApertureInq	8x 09 04 42 FF	y0 50 00 00 0p 0q FF	pq: Aperture Gain
CAM_PictureEffectModeInq	8x 09 04 63 FF	y0 50 00 FF	Off
		y0 50 04 FF	B&W
CAM_MemoryInq	8x 09 04 3F FF	y0 50 0p FF	p: Memory number last operated.
SYS_MenuModeInq	8x 09 06 06 FF	y0 50 02 FF	On
		y0 50 03 FF	Off
CAM_LR_ReverseInq	8x 09 04 61 FF	y0 50 02 FF	On
		y0 50 03 FF	Off
CAM_PictureFlipInq	8x 09 04 66 FF	y0 50 02 FF	On
		y0 50 03 FF	Off
CAM_ColorSaturationInq	8x 09 04 49 FF	y0 50 00 00 00 0p FF	p: Color Gain setting 0h (60%) to Eh (130%)
CAM_IDInq	8x 09 04 22 FF	y0 50 0p FF	p: Gamma ID
IR_ReceiveInq	8x 09 06 08 FF	y0 50 02 FF	On
		y0 50 03 FF	Off
IR_ReceiveReturn		y0 07 7D 01 04 00 FF	Power ON/OFF
		y0 07 7D 01 04 07 FF	Zoom tele/wide
		y0 07 7D 01 04 38 FF	AF ON/OFF
		y0 07 7D 01 04 33 FF	Camera _Backlight
		y0 07 7D 01 04 3F FF	Camera _Memery
		y0 07 7D 01 06 01 FF	Pan_titleDriver
CAM_BrightnessInq	8x 09 04 A1 FF	y0 50 00 00 0p 0q FF	pq: Brightness Position
CAM_ContrastInq	8x 09 04 A2 FF	y0 50 00 00 0p 0q FF	pq: Contrast Position
CAM_FlipInq	8x 09 04 A4 FF	y0 50 00 FF	Off
		y0 50 01 FF	Flip-H
		y0 50 02 FF	Flip-V
		y0 50 03 FF	Flip-HV
CAM_GammaInq	8x 09 04 5B FF	y0 50 0p FF	p: Gamma setting
CAM_VersionInq	8x 09 00 02 FF	y0 50 ab cd mn pq rs tu vw FF	ab cd : vender ID (0220) mn pq : model ID ST (0510) 、 U2(0512)、U3 (0513) rs tu : ARM Version vw : reserve
VideoSystemInq	8x 09 06 23 FF	y0 50 0p FF	P: 0~E Video format 0:1080P60 8:720P30 1:1080P50 9:720P25 2:1080i60 A: 1080P59.94 3:1080i50 B: 1080i59.94 4:720P60 C: 720P59.94 5:720P50 D: 1080P29.97 6:1080P30 E: 720P29.97 7:1080P25
Pan-tiltMaxSpeedInq	8x 09 06 11 FF	y0 50 ww zz FF	ww: Pan Max Speed zz: Tilt Max Speed
Pan-tiltPosInq	8x 09 06 12 FF	y0 50 0w 0w 0w 0w 0z 0z 0z 0z FF	www: Pan Position zzzz: Tilt Position

Note: [X] in the above table indicates the camera address to be operated, **【y】 = 【x + 8】** .

5.2 Pelco-D Protocol Command List

Function	Byte1	Byte2	Byte3	Byte4	Byte5	Byte6	Byte7
Up	0xFF	Address	0x00	0x08	Pan Speed	Tilt Speed	SUM
Down	0xFF	Address	0x00	0x10	Pan Speed	Tilt Speed	SUM
Left	0xFF	Address	0x00	0x04	Pan Speed	Tilt Speed	SUM
Right	0xFF	Address	0x00	0x02	Pan Speed	Tilt Speed	SUM
Upleft	0xFF	Address	0x00	0x0C	Pan Speed	Tilt Speed	SUM
Upright	0xFF	Address	0x00	0x0A	Pan Speed	Tilt Speed	SUM
DownLeft	0xFF	Address	0x00	0x14	Pan Speed	Tilt Speed	SUM
DownRight	0xFF	Address	0x00	0x12	Pan Speed	Tilt Speed	SUM
Zoom In	0xFF	Address	0x00	0x20	0x00	0x00	SUM
Zoom Out	0xFF	Address	0x00	0x40	0x00	0x00	SUM
Focus Far	0xFF	Address	0x00	0x80	0x00	0x00	SUM
Focus Near	0xFF	Address	0x01	0x00	0x00	0x00	SUM
Stop	0xFF	Address	0x00	0x00	0x00	0x00	SUM
Set Preset	0xFF	Address	0x00	0x03	0x00	Preset ID	SUM
Clear Preset	0xFF	Address	0x00	0x05	0x00	Preset ID	SUM
Call Preset	0xFF	Address	0x00	0x07	0x00	Preset ID	SUM
Query Pan Position	0xFF	Address	0x00	0x51	0x00	0x00	SUM
Query Pan Position Response	0xFF	Address	0x00	0x59	Value High Byte	Value Low Byte	SUM
Query Tilt Position	0xFF	Address	0x00	0x53	0x00	0x00	SUM
Query Tilt Position Response	0xFF	Address	0x00	0x5B	Value High Byte	Value Low Byte	SUM
Query Zoom Position	0xFF	Address	0x00	0x55	0x00	0x00	SUM
Query Zoom Position Response	0xFF	Address	0x00	0x5D	Value High Byte	Value Low Byte	SUM

5.3 Pelco-P Protocol Command List

Function	Byte1	Byte2	Byte3	Byte4	Byte5	Byte6	Byte7	Byte8
Up	0xA0	Address	0x00	0x08	Pan Speed	Tilt Speed	0xAF	XOR
Down	0xA0	Address	0x00	0x10	Pan Speed	Tilt Speed	0xAF	XOR
Left	0xA0	Address	0x00	0x04	Pan Speed	Tilt Speed	0xAF	XOR
Right	0xA0	Address	0x00	0x02	Pan Speed	Tilt Speed	0xAF	XOR
Upleft	0xA0	Address	0x00	0x0C	Pan Speed	Tilt Speed	0xAF	XOR
Upright	0xA0	Address	0x00	0x0A	Pan Speed	Tilt Speed	0xAF	XOR
DownLeft	0xA0	Address	0x00	0x14	Pan Speed	Tilt Speed	0xAF	XOR
DownRight	0xA0	Address	0x00	0x12	Pan Speed	Tilt Speed	0xAF	XOR
Zoom In	0xA0	Address	0x00	0x20	0x00	0x00	0xAF	XOR

Zoom Out	0xA0	Address	0x00	0x40	0x00	0x00	0xAF	XOR
Stop	0xA0	Address	0x00	0x00	0x00	0x00	0xAF	XOR
Focus Far	0xA0	Address	0x01	0x00	0x00	0x00	0xAF	XOR
Focus Near	0xA0	Address	0x02	0x00	0x00	0x00	0xAF	XOR
Set Preset	0xA0	Address	0x00	0x03	0x00	Preset ID	0xAF	XOR
Clear Preset	0xA0	Address	0x00	0x05	0x00	Preset ID	0xAF	XOR
Call Preset	0xA0	Address	0x00	0x07	0x00	Preset ID	0xAF	XOR
Query Pan Position	0xA0	Address	0x00	0x51	0x00	0x00	0xAF	XOR
Query Pan Position Response	0xA0	Address	0x00	0x59	Value High Byte	Value Low Byte	0xAF	XOR
Query Tilt Position	0xA0	Address	0x00	0x53	0x00	0x00	0xAF	XOR
Query Tilt Position Response	0xA0	Address	0x00	0x5B	Value High Byte	Value Low Byte	0xAF	XOR
Query Zoom Position	0xA0	Address	0x00	0x55	0x00	0x00	0xAF	XOR
Query Zoom Position Response	0xA0	Address	0x00	0x5D	Value High Byte	Value Low Byte	0xAF	XOR

6. Maintenance and Troubleshooting

6.1 Camera Maintenance

- 1) Please power off the camera and disconnect the power adapter and socket, if it's not used for a long run.
- 2) Use soft cloth or tissue to clean the camera cover.
- 3) Wipe it with a soft, dry cloth when cleaning the camera lens. Wipe it gently with a mild detergent if needed. Do not use strong or corrosive detergents to avoid scratching the lens and affecting the video quality.

6.2 Troubleshooting

1) No video output

- a. Check whether the camera power supply is connected, the voltage is normal, the power indicator is lit.
- b. Whether the machine could do self-check after restarted.
- c. Check whether the bottom of the DIP switch is the normal operating mode (see Table 2.2 and Table 2.3)
- d. Check whether the video output cable or video display is normal

2) No image sometimes

- a. Check whether the video output cable or video display is normal

3) Video dithering when zoom-in or zoom-out

- a. Check whether the camera installation position is solid
- b. Whether there is shaking machine or objects around the camera

4) Remote control not works

- a. Remote control address is set to 1 (if the machine is set back to the factory defaults, remote control addresses need to be back to 1 too)
- b. Check whether the battery is installed on the remote controller or low.
- c. Check the camera working mode is the normal operating mode (see Table 2.2 and Table 2.3)
- d. Check the menu whether is closed, camera control through remote controller is only available after exiting the menu. If video output from LAN, menu will not be displayed, menu will automatically exists 30s later, and then it can be controlled by remote controller.

5) Serial port not works

- a. Check whether the camera serial device protocol, baud rate, address is consistent
- b. Check whether the control cable is connected properly
- c. Check whether the camera working mode is the normal operating mode

6) Web pages cannot log in

- a. Check if the camera outputs video normally by connecting directly to the screen.
- b. Check whether the network cable is connected properly (Ethernet port yellow light flashes to indicate normal network cable connection)
- c. Check whether your computer is added the segment and the segment is consistent with the IP address of the camera
- d. Click "Start" and select "Run" and then type "cmd" in the computer; Click "OK" then turn on a DOS command window to enter ping 192.168.5.163. Press the Enter key to appear message as follows: Description network connection is normal.

```
C:\Users\qq214>ping 192.168.5.163

Pinging 192.168.5.163 with 32 bytes of data:
Reply from 192.168.5.163: bytes=32 time=2ms TTL=64
Reply from 192.168.5.163: bytes=32 time=1ms TTL=64
Reply from 192.168.5.163: bytes=32 time<1ms TTL=64
Reply from 192.168.5.163: bytes=32 time=4ms TTL=64

Ping statistics for 192.168.5.163:
    Packets: Sent = 4, Received = 4, Lost = 0 (0% loss),
    Approximate round trip times in milli-seconds:
        Minimum = 0ms, Maximum = 4ms, Average = 1ms

C:\Users\qq214>_
```

7. Copyright Statement

All the contents in this manual and its copyright are owned by the company. No one is allowed to imitate, copy, or translate this manual without the company's permission. This manual contains no guarantee, standpoint expression or other implies in any form. Product specification and information in this manual is for reference only and subject to change without notice.

All rights reserved. No reproducing is allowed without acknowledgement.